

**PITAGONE** anti-ram vehicle barriers are designed, developed and produced in Belgium





The **PITAGONE F18** was tested in its fully operational position

• **FUNCTIONAL MOBILITY SYSTEM** •

Observation after each Crash-Test: **Engine destroyed | Vehicle Disabled**

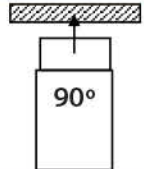

Head-on attack

   <b>FUNCTIONAL MOBILITY SYSTEM</b>			
Test Designation	Vehicle Mass	Test Speed	Test Angle
N3/N3C	7.5-18T 	48 km/h	90° 



Offset attack

Tested by the German authorities  <b>FUNCTIONAL MOBILITY SYSTEM</b>		
Test Designation	Vehicle Mass	Test Speed
N3/N3C CP1S	12T 	42 km/h
Test angle		



Side-on attack (45°)

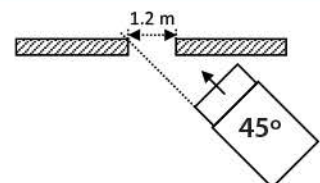
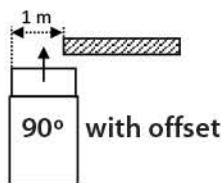

**ADVANTAGES:**

- 1 • Unique, mobile solution against ram vehicles.
- 2 • Tested with functional mobile system.
- 3 • Ultra-fast assembly, does not require any tools.
- 4 • Easy storage and transport (Rack and SecurityBox).
- 5 • Long life cycle, minimal maintenance.
- 6 • Model does not cause panic.
- 7 • Energy and lateral shock absorption.
- 8 • Adjustable to two widths.
- 9 • Easy assembly by one person.

**RAPID ASSEMBLY**



**COLOUR/BRANDING CUSTOMISATION**







### SPECIFICATIONS :

- Height **100 cm**
- Width **9 cm**
- Depth **104 cm**
- Total weight **38,5 Kg**

### Distance between the modules:

- Liaison bars in position 25 **43,5 cm**
- Liaison bars in position 50 **68 cm**

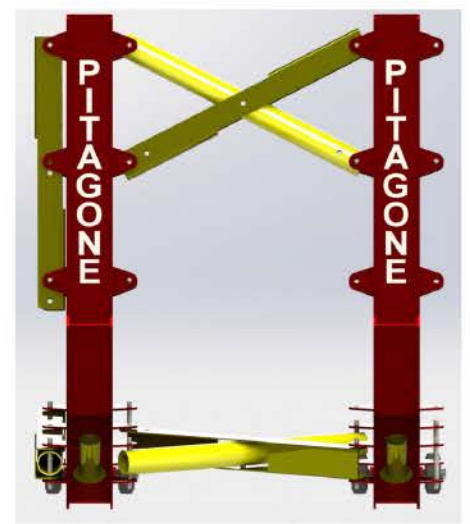
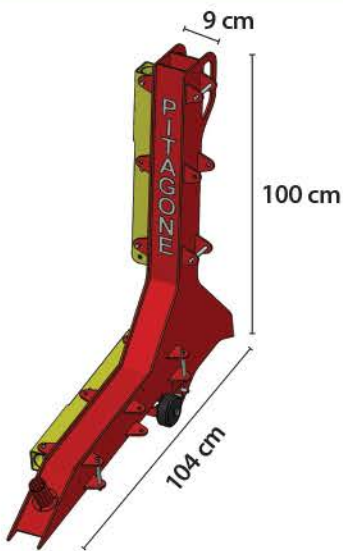

### RACK F18

- Resistant to the harshest usage conditions.
- An operational productivity time-saver.
- More efficient use of space in your warehouses.
- Significant reduction in transport costs.
- Quick and easy to handle.
- Prevents: theft, breakage and loss.
- Dimensions : 137 cm x 108 cm x 120 cm
- Net weight : 95 kg / Weight with 6 modules : 326 kg

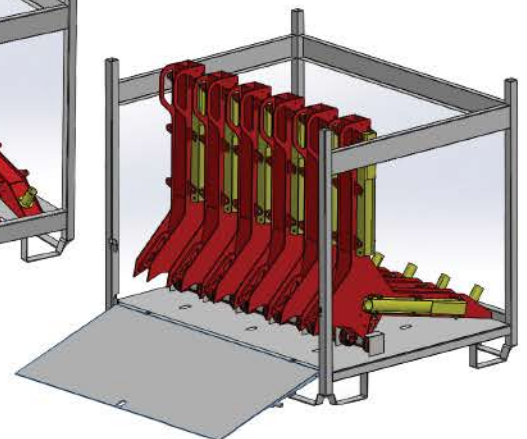
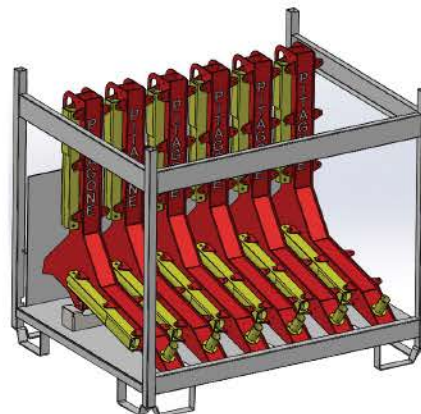

- +32 488 61 66 17
- +32 2 588 77 93
- +33 1 76 64 13 72

www.bretholz.solutions  
simon@bretholz.solutions

Order in  
multiples of 6





**THE CONTAINER BEST SUITED TO THE STORAGE AND TRANSPORT OF YOUR F18**

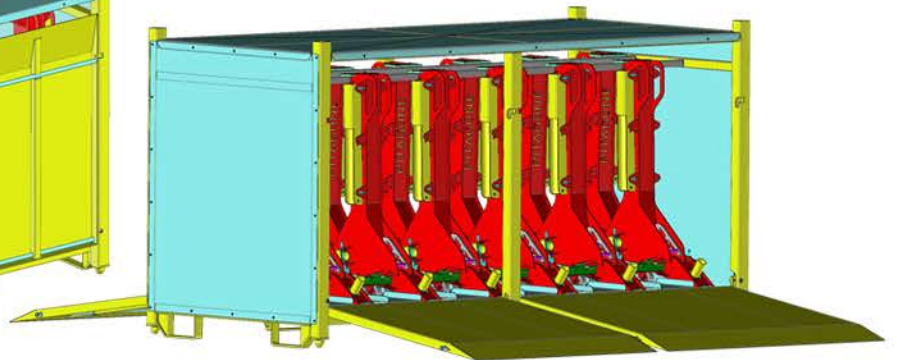

**CONTAINER DIMENSIONS**

- Length **2,5 m**
- Width **1,2 m**
- Height **1,35 m**
- Net weight **415 kg**
- Weight with 12 modules **877 kg**

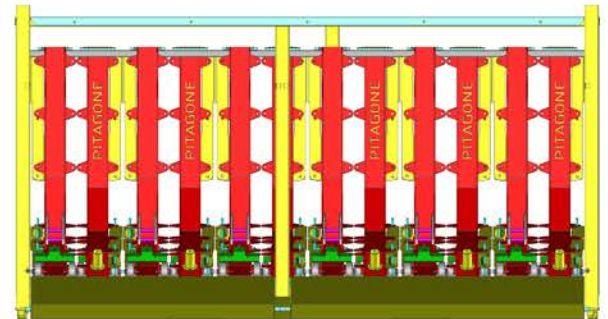

- Allows better use of space in your warehouses and a significant reduction in transport costs.
- Quick and easy to handle.
- Galvanised steel chassis.
- These containers can be customised with the name of your company.
- Protect F18 from weather disruptions and avoid theft, breakage and loss.

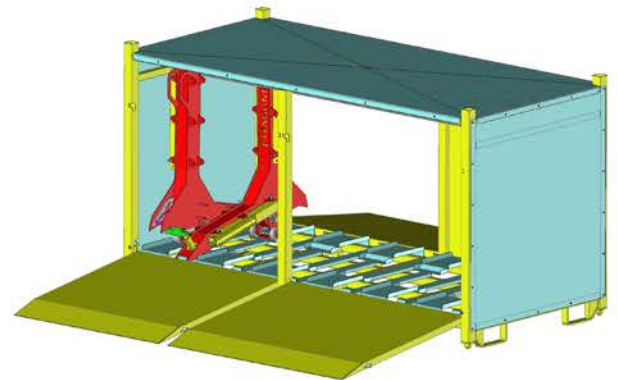

**THE OPERATIONAL SOLUTION FOR YOUR PITAGONE BARRIERS**



- ☎ +32 488 61 66 17
- ☎ +32 2 588 77 93
- ☎ +33 1 76 64 13 72

[www.bretholz.solutions](http://www.bretholz.solutions)  
[simon@bretholz.solutions](mailto:simon@bretholz.solutions)